



City Council  
**COMMITTEE OF THE WHOLE**  
*City of Belvidere, Illinois*

Aldersperson Clayton Stevens	Chairman Building
Aldersperson John Albertini	Vice-Chairman Building
Aldersperson Wendy Frank	Chairman Finance and Personnel
Aldersperson Ric Brereton	Vice-Chairman Finance and Personnel
Aldersperson Mike McGee	Chairman Planning & Zoning
Aldersperson Matthew Fleury	Vice-Chairman Planning & Zoning
Aldersperson Rory Peterson	Chairman Public Safety
Aldersperson Jerry Hoiness	Vice-Chairman Public Safety
Aldersperson Sandra Gramkowski	Chairman Public Works
Aldersperson Chris Montalbano	Vice-Chairman Public Works

**AGENDA**

May 11, 2026  
6:00 p.m.  
City Council Chambers  
401 Whitney Blvd., Belvidere, Illinois

Call to Order:

Roll Call:

Public Comment:

Public Forum:

(A) National Police Week Proclamation.

Reports of Officers, Boards, and Special Committees:

1. Building, Planning & Zoning, Unfinished Business: None.
  
2. Building, Planning & Zoning, New Business:
  - A. Building Department – Update.
  - B. Planning Department – Update.
  - C. Re-appointment of Daniel Druckrey to the Belvidere Planning & Zoning Commission.
  - D. Re-appointment of Arthur Hyland to the Belvidere Planning & Zoning Commission.
  - E. Re-appointment of Kimberly Coniglio to the Belvidere Historic Preservation Commission.
  - F. Re-appointment of Sonya Dobberfuhl to the Belvidere Historic Preservation Commission.
  - G. Resolution in Support of Municipal Housing Authority.
  
3. Public Works, Unfinished Business: None.
  
4. Public Works, New Business:
  - A. Public Works Department – Update.
  - B. Notice of Funding: FRA Railroad Crossing Elimination Program.
  - C. Parking Lot #7 Expansion and Enhancement Grant Projects – Material Testing.
  - D. Purchase of Wheeled Excavator – Street Department.
  - E. Purchase of Mini Excavator – Street Department.
  
5. Other, Unfinished Business: None.
  
6. Other, New Business:
  - A. Executive Session pursuant to Section 2(c)(1) of the Open Meetings Act to discuss appointment, employment, and compensation of a specific employee.
  - B. Appointment of Director of Buildings.
  
7. Adjournment:

## **MEMO**

**DATE:** April 20, 2026  
**TO:** City Council and Clerk  
**FROM:** Mayor Clinton Morris  
**RE:** Reappointment of Daniel Druckrey

The Belvidere Planning and Zoning Commission is comprised of seven (7) members, each serving a five-year term. Daniel Druckrey is serving a term that expires in May and has agreed to serve another five-year term (ending 2031). He has a long history of serving the community through various roles.

**Requested Motion:** Motion to consent to and approve the appointment of Mr. Daniel Druckrey to the Belvidere Planning and Zoning Commission for a five-year term, ending in May 2031.

April 2, 2021

My term on Belvidere  
City Planning and Zoning  
Commission is ending

I would like to be  
reappointed to the  
Commission

Daniel Drudey

## **MEMO**

**DATE:** April 20, 2026  
**TO:** City Council and Clerk  
**FROM:** Mayor Clinton Morris  
**RE:** Reappointment of Arthur Hyland

The Belvidere Planning and Zoning Commission is comprised of seven (7) members, each serving a five-year term. Arthur Hyland is serving a term that expires in May and has agreed to serve another five-year term (ending 2031). He has a long history of serving the community through various roles.

**Requested Motion:** Motion to consent to and approve the appointment of Mr. Arthur Hyland to the Belvidere Planning and Zoning Commission for a five-year term, ending in May 2031.

TO IT MAY CONCERN

I WOULD LIKE TO SERVE ANOTHER  
TERM ON THE PLANNING AND ZONING BOARD.

Arthur Kyland

## **MEMO**

**DATE:** April 20, 2026  
**TO:** City Council and Clerk  
**FROM:** Mayor Clinton Morris  
**RE:** Re-Appointment of Kimberly Coniglio to the Belvidere Historic Preservation Commission

The Belvidere Historic Preservation Commission is comprised of seven (7) members, each serving a 3-year term. Kimberly Coniglio is serving a term that expires April 30, 2026. Kimberly Coniglio is currently the acting vice-chair of the Commission and has been helpful in organizing events. Ms. Coniglio has agreed to serve another three-year term (ending in 2029).

**Requested Motion:** Motion to consent to and approve the appointment of Ms. Kimberly Coniglio to the Belvidere Historic Preservation Commission for a three-year term, ending in April 30, 2029.

## Gina DelRose

---

**From:** Kimberly Coniglio  
**Sent:** Friday, April 3, 2026 1:29 PM  
**To:** Gina DelRose  
**Subject:** Historic Preservation Membership

This message originated from an **External Source**. DO NOT click links or open attachments unless you recognize the sender and know the content is safe.

Hi Gina:

I would like to continue my membership with the Historic Preservation Commission.

You're a outstanding leader!!

Kimberly Coniglio

## **MEMO**

**DATE:** April 20, 2026  
**TO:** City Council and Clerk  
**FROM:** Mayor Clinton Morris  
**RE:** Reappointment of Sonya Dobberfuhl

The Belvidere Historic Preservation Commission is comprised of seven (7) members, each serving a 3-year term. Sonya Dobberfuhl is serving a term that expires April 30, 2029. Sonya Dobberfuhl previously held the chairmanship position and authored the A Walk Through Time book which has been a successful fundraiser for the Commission. Ms. Dobberfuhl has agreed to serve another three-year term (ending in 2029).

**Requested Motion:** Motion to consent to and approve the appointment of Ms. Sonya Dobberfuhl to the Belvidere Historic Preservation Commission for a three-year term, ending in April 30, 2029.

I want to be reappointed  
with the Historic Preservation  
Commission

Inna  
Dobberfuhl

**RESOLUTION # \_\_\_\_\_**

**A RESOLUTION OF THE CITY OF BELVIDERE  
IN SUPPORT OF MUNICIPAL HOUSING AUTHORITY**

**WHEREAS**, the City of Belvidere (the City) has the responsibility to promote public health, safety and general welfare by regulating land use, density and development standards within the City; and

**WHEREAS**, the City recognizes that Municipal Authority of land use and zoning is a means to address separating incompatible land uses, protecting property values, managing traffic flow, ensuring adequate infrastructure and guiding orderly community growth; and

**WHEREAS**, in 2024 the City updated its Comprehensive Land Use Plan in which inputs received from thousands of hours of staff research, public outreach, hearings and consensus-building were utilized to provide for the character of the city desired and deserved by our citizens; and

**WHEREAS**, our Comprehensive Land Use Plan process has debated and disposed of the measures recently proposed in the legislature that would also centralize all such decisions; and

**WHEREAS**, the government and public investment in local planning essential for the continuing community vitality of the City is only possible when the people making these decisions are the ones actually accountable for their results; and

**WHEREAS**, maintaining Municipal Housing Authority prevents destructive, ill-informed decisions made by others from outside the local community that may impede and prevent those entrusted to represent their community and protect their residents' greatest primary asset; and

**WHEREAS**, Municipal Housing Authority already possesses the authority to adopt any of the Build Act initiatives if local elected officials find them beneficial to adopt in their City; and

**WHEREAS**, affordable housing remedies are never going to be supplied by remote levels of big government's intrusion that ignores what government action did to cause the affordability problem in the first place; and

**WHEREAS**, usurping Municipal Housing Authority will forever strip the local voters' right to be heard or to be able to amend in the future housing decisions made by outsiders rather than local municipal authority; and

**WHEREAS**, circumventing Municipal Housing Authority violates local residents trust that they are able to hold their local elected officials accountable for housing decisions detrimental to them. Preserving voter's rights to enact and amend all local land use decisions is essential to protection of their investment; and

**WHEREAS**, support of Municipal Housing Authority wisely recognizes each community is unique throughout the State of Illinois and those local residents most impacted by land use decisions have always had and must always have the authority for rendering them.

**NOW, THEREFORE, be it resolved by the City Council of Belvidere as follows:**

**Section 1.** The foregoing recitals shall be and are hereby incorporated as findings of fact as if said recitals were fully set forth herein.

**Section 2.** The City urges the Illinois General Assembly and Governor to preserve municipal authority for land use and zoning in its current form without additional restrictions on municipal governments and the communities they serve.

**Section 3.** The City Clerk shall forward a copy of this Resolution to the Illinois Municipal League.

Adopted by the City Council of the City of Belvidere, Illinois, this \_\_\_\_\_ date of \_\_\_\_\_, 2026

Ayes:

Nays:

Absent:

Date Approved:

Approved:

\_\_\_\_\_ Mayor

Attest:

\_\_\_\_\_ City Clerk

# Memo

**To:** Mayor and City Council  
**From:** Brent Anderson, Director of Public Works  
**Date:** 5/6/2026  
**Re:** U.S. Department of Transportation  
Notice of Funding Opportunity: FRA Railroad Crossing Elimination Program

---

The United States Department of Transportation has issued a Notice of Funding Opportunity for their 2026 FRA Grade Crossing Elimination Program. The current cost estimate to complete design engineering of this project is \$3,500,000.00. Grant applications are due by 5:00 P.M. on June 8, 2026. Attached to this memo is a proposal from Hampton, Lenzini & Renwick, our certified bridge manager, in the amount of \$3,600.00, to complete the grant application for Phase II Design Engineering Funding. Their work will include an updated cost estimate for the construction of this project.

I would recommend approval of the proposal from Hampton, Lenzini & Renwick, in an amount not-to-exceed \$3,600.00, to complete the FRA Railroad Crossing Elimination Program grant application for the Appleton Road Grade Separation Project. This work will be paid for from Line Item #41-5-110-8025.



Using Federal Funds?  Yes  No

Agreement For:  Agreement Type:  Number:

LOCAL PUBLIC AGENCY

Local Public Agency:  County:  Section Number:  Job Number:

Project Number:  Contact Name:  Phone Number:  Email:

SECTION PROVISIONS

Local Street/Road Name:  Key Route:  Length:  Structure Number:

Location Termini:

Project Description:

Engineering Funding:  MFT/TBP  State  Other

Anticipated Construction Funding:  Federal  MFT/TBP  State  Other

AGREEMENT FOR

Phase I - Preliminary Engineering  Phase II - Design Engineering  Phase III - Construction Engineering

CONSULTANT

Prime Consultant (Firm) Name:  Contact Name:  Phone Number:  Email:

Address:  City:  State:  Zip Code:

THIS AGREEMENT IS MADE between the above Local Public Agency (LPA) and Consultant (ENGINEER) and covers certain professional engineering services in connection with the improvement of the above SECTION. Project funding allotted to the LPA by the State of Illinois under the general supervision of the State Department of Transportation, hereinafter called the "DEPARTMENT," will be used entirely or in part to finance ENGINEERING services as described under AGREEMENT PROVISIONS.

Since the services contemplated under the AGREEMENT are professional in nature, it is understood that the ENGINEER, acting as an individual, partnership, firm or legal entity, qualifies for professional status and will be governed by professional ethics in its relationship to the LPA and the DEPARTMENT. The LPA acknowledges the professional and ethical status of the ENGINEER by entering into an AGREEMENT on the basis of its qualifications and experience and determining its compensation by mutually satisfactory negotiations.

WHEREVER IN THIS AGREEMENT or attached exhibits the following terms are used, they shall be interpreted to mean:

- Regional Engineer: Deputy Director, Office of Highways Project Implementation, Regional Engineer, Department of Transportation
- Resident Construction Supervisor: Authorized representative of the LPA in immediate charge of the engineering details of the construction PROJECT
- In Responsible Charge Contractor: A full time LPA employee authorized to administer inherently governmental PROJECT activities Company or Companies to which the construction contract was awarded

## AGREEMENT EXHIBITS

The following EXHIBITS are attached hereto and made a part of hereof this AGREEMENT:

- EXHIBIT A: Scope of Services
- EXHIBIT B: Project Schedule
- EXHIBIT C: Qualification Based Selection (QBS) Checklist
- EXHIBIT D: Cost Estimate of Consultant Services (BLR 05513 or BLR 05514 )
- EXHIBIT \_\_\_ : Direct Costs Check Sheet (attach BDE 436 when using Lump Sum on Specific Rate Compensation)
- HLR Hourly Rate Schedule 2026
- \_\_\_\_\_
- \_\_\_\_\_

### I. THE ENGINEER AGREES,

1. To perform or be responsible for the performance of the Scope of Services presented in EXHIBIT A for the LPA in connection with the proposed improvements herein before described.
2. The Classifications of the employees used in the work shall be consistent with the employee classifications and estimated staff hours. If higher-salaried personnel of the firm, including the Principal Engineer, perform services that are to be performed by lesser-salaried personnel, the wage rate billed for such services shall be commensurate with the payroll rate for the work performed.
3. That the ENGINEER shall be responsible for the accuracy of the work and shall promptly make necessary revisions or corrections required as a result of the ENGINEER'S error, omissions or negligent acts without additional compensation. Acceptance of work by the LPA or DEPARTMENT will not relieve the ENGINEER of the responsibility to make subsequent correction of any such errors or omissions or the responsibility for clarifying ambiguities.
4. That the ENGINEER will comply with applicable Federal laws and regulations, State of Illinois Statutes, and the local laws or ordinances of the LPA.
5. To pay its subconsultants for satisfactory performance no later than 30 days from receipt of each payment from the LPA.
6. To invoice the LPA, The ENGINEER shall submit all invoices to the LPA within three months of the completion of the work called for in the AGREEMENT or any subsequent Amendment or Supplement.
7. The ENGINEER or subconsultant shall not discriminate on the basis of race, color, national origin or sex in the performance of this AGREEMENT. The ENGINEER shall carry out applicable requirements of 49 CFR part 26 in the administration of US Department of Transportation (US DOT) assisted contract. Failure by the Engineer to carry out these requirements is a material breach of this AGREEMENT, which may result in the termination of this AGREEMENT or such other remedy as the LPA deems appropriate.
8. That none of the services to be furnished by the ENGINEER shall be sublet, assigned or transferred to any other party or parties without written consent of the LPA. The consent to sublet, assign or otherwise transfer any portion of the services to be furnished by the ENGINEER shall be construed to relieve the ENGINEER of any responsibility for the fulfillment of this AGREEMENT.
9. For Preliminary Engineering Contracts:
  - (a) To attend meetings and visit the site of the proposed improvement when requested to do so by representatives of the LPA or the DEPARTMENT, as defined in Exhibit A (Scope of Services).
  - (b) That all plans and other documents furnished by the ENGINEER pursuant to the AGREEMENT will be endorsed by the ENGINEER and affixed the ENGINEER's professional seal when such seal is required by law. Such endorsements must be made by a person, duly licensed or registered in the appropriate category by the Department of Professional Regulation of the State of Illinois. It will be the ENGINEER's responsibility to affix the proper seal as required by the Bureau of Local Roads and Streets manual published by the DEPARTMENT.
  - (c) That the ENGINEER is qualified technically and is thoroughly conversant with the design standards and policies applicable for the PROJECT; and that the ENGINEER has sufficient properly trained, organized and experienced personnel to perform the services enumerated in Exhibit A (Scope of Services).
10. That the engineering services shall include all equipment, instruments, supplies, transportation and personnel required to perform the duties of the ENGINEER in connection with this AGREEMENT (See DIRECT COST tab in BLR 05513 or BLR 05514).

### II. THE LPA AGREES,

1. To certify by execution of this AGREEMENT that the selection of the ENGINEER was performed in accordance with the Professional Services Selection Act (50 ILCS 510) (Exhibit C).
2. To furnish the ENGINEER all presently available survey data, plans, specifications, and project information.
3. To pay the ENGINEER:
  - (a) For progressive payments - Upon receipt of monthly invoices from the ENGINEER and the approval thereof by the LPA, monthly payments for the work performed shall be due and payable to the ENGINEER, such payments to be equal to the value of the partially completed work minus all previous partial payments made to the ENGINEER.
  - (b) Final payment - Upon approval of the work by the LPA but not later than 60 days after the work is completed and reports have been made and accepted by the LPA and DEPARTMENT a sum of money equal to the basic fee as determined in this AGREEMENT less the total of the amount of partial payments previously paid to the ENGINEER

shall be due and payable to the ENGINEER.

(c) For Non-Federal County Projects - (605 ILCS 5/5-409)

- (1) For progressive payments - Upon receipt of monthly invoices from the ENGINEER and the approval thereof by the LPA, monthly payments for the work performed shall be due and payable to the ENGINEER. Such payments to be equal to the value of the partially completed work in all previous partial payments made to the ENGINEER.
- (2) Final payment - Upon approval of the work by the LPA but not later than 60 days after the work is completed and reports have been made and accepted by the LPA and STATE, a sum of money equal to the basic fee as determined in the AGREEMENT less the total of the amount of partial payments previously paid to the ENGINEER shall be due and payable to the ENGINEER.

4. To pay the ENGINEER as compensation for all services rendered in accordance with the AGREEMENT on the basis of the following compensation method as discussed in 5-5.10 of the BLR Manual.

Method of Compensation:

Percent

Lump Sum

Specific Rate \$3,600.00 (Maximum Fee \$150,000)

Cost plus Fixed Fee:

Total Compensation = DL + DC + OH + FF

Where:

DL is the total Direct Labor,

DC is the total Direct Cost,

OH is the firm's overhead rate applied to their DL and

FF is the Fixed Fee.

Where FF = ( 0.33 + R ) DL + %SubDL, where R is the advertised Complexity Factor and %SubDL is 10% profit allowed on the direct labor of the subconsultants.

The Fixed Fee cannot exceed 15% of the DL + OH.

5. The recipient shall not discriminate on the basis of race, color, national origin or sex in the award and performance of any US DOT-assisted contract or in the administration of its DBE program or the requirements of 49 CFR part 26. The recipient shall take all necessary and reasonable steps under 49 CFR part 26 to ensure nondiscrimination in the award and administration of US DOT-assisted contracts. The recipient's DBE program, as required by 49 CFR part 26 and as approved by US DOT, is incorporated by reference in this agreement. Implementation of this program is a legal obligation and failure to carry out its terms shall be treated as violation of this AGREEMENT. Upon notification to the recipient of its failure to carry out its approved program, the Department may impose sanctions as provided for under part 26 and may, in appropriate cases, refer the matter for enforcement under 18 U.S.C. 1001 and/or the Program Fraud Civil Remedies Act of 1986 (31 U.S.C 3801 et seq.).

### III. IT IS MUTUALLY AGREED,

1. To maintain, for a minimum of 3 years after the completion of the contract, adequate books, records and supporting documents to verify the amount, recipients and uses of all disbursements of funds passing in conjunction with the contract; the contract and all books, records and supporting documents related to the contract shall be available for review and audit by the Auditor General, and the DEPARTMENT; the Federal Highways Administration (FHWA) or any authorized representative of the federal government, and to provide full access to all relevant materials. Failure to maintain the books, records and supporting documents required by this section shall establish a presumption in favor of the DEPARTMENT for the recovery of any funds paid by the DEPARTMENT under the contract for which adequate books, records and supporting documentation are not available to support their purported disbursement.
2. That the ENGINEER shall be responsible for any all damages to property or persons out of an error, omission and/or negligent act in the prosecution of the ENGINEER's work and shall indemnify and save harmless the LPA, the DEPARTMENT, and their officers, agents and employees from all suits, claims, actions or damages liabilities, costs or damages of any nature whatsoever resulting there from. These indemnities shall not be limited by the listing of any insurance policy.  

The LPA will notify the ENGINEER of any error or omission believed by the LPA to be caused by the negligence of the ENGINEER as soon as practicable after the discovery. The LPA reserves the right to take immediate action to remedy any error or omission if notification is not successful; if the ENGINEER fails to reply to a notification; or if the conditions created by the error or omission are in need of urgent correction to avoid accumulation of additional construction costs or damages to property and reasonable notice is not practicable.
3. This AGREEMENT may be terminated by the LPA upon giving notice in writing to the ENGINEER at the ENGINEER's last known post office address. Upon such termination, the ENGINEER shall cause to be delivered to the LPA all drawings, plats, surveys, reports, permits, agreements, soils and foundation analysis, provisions, specifications, partial and completed estimates and data, if any from soil survey and subsurface investigation with the understanding that all such materials becomes the property of the LPA. The LPA will be responsible for reimbursement of all eligible expenses incurred under the terms of this AGREEMENT up to the date of the written notice of termination.

4. In the event that the DEPARTMENT stops payment to the LPA, the LPA may suspend work on the project. If this agreement is suspended by the LPA for more than thirty (30) calendar days, consecutive or in aggregate, over the term of this AGREEMENT, the ENGINEER shall be compensated for all services performed and reimbursable expenses incurred prior to receipt of notice of suspension. In addition, upon the resumption of services the LPA shall compensate the ENGINEER, for expenses incurred as a result of the suspension and resumption of its services, and the ENGINEER's schedule and fees for the remainder of the project shall be equitably adjusted.
5. This AGREEMENT shall continue as an open contract and the obligations created herein shall remain in full force and effect until the completion of construction of any phase of professional services performed by others based upon the service provided herein. All obligations of the ENGINEER accepted under this AGREEMENT shall cease if construction or subsequent professional services are not commenced within 5 years after final payment by the LPA.
6. That the ENGINEER shall be responsible for any and all damages to property or persons arising out of an error, omission and/or negligent act in the prosecution of the ENGINEER's work and shall indemnify and have harmless the LPA, the DEPARTMENT, and their officers, employees from all suits, claims, actions or damages liabilities, costs or damages of any nature whatsoever resulting there from. These indemnities shall not be limited by the listing of any insurance policy.
7. The ENGINEER and LPA certify that their respective firm or agency:
  - (a) has not employed or retained for commission, percentage, brokerage, contingent fee or other considerations, any firm or person (other than a bona fide employee working solely for the LPA or the ENGINEER) to solicit or secure this AGREEMENT,
  - (b) has not agreed, as an express or implied condition for obtaining this AGREEMENT, to employ or retain the services of any firm or person in connection with carrying out the AGREEMENT or
  - (c) has not paid, or agreed to pay any firm, organization or person (other than a bona fide employee working solely for the LPA or the ENGINEER) any fee, contribution, donation or consideration of any kind for, or in connection with, procuring or carrying out the AGREEMENT.
  - (d) that neither the ENGINEER nor the LPA is/are not presently debarred, suspended, proposed for debarment, declared ineligible or voluntarily excluded from covered transactions by any Federal department or agency,
  - (e) has not within a three-year period preceding the AGREEMENT been convicted of or had a civil judgment rendered against them for commission of fraud or criminal offense in connection with obtaining, attempting to obtain or performing a public (Federal, State or local) transaction; violation of Federal or State antitrust statutes or commission of embezzlement, theft, forgery, bribery, falsification or destruction of records, making false statements or receiving stolen property.
  - (f) are not presently indicated for or otherwise criminally or civilly charged by a government entity (Federal, State, or local) with commission of any of the offenses enumerated in paragraph and
  - (g) has not within a three-year period preceding this AGREEMENT had one or more public transaction (Federal, State, local) terminated for cause or default.

Where the ENGINEER or LPA is unable to certify to any of the above statements in this clarification, an explanation shall be attached to this AGREEMENT.

8. In the event of delays due to unforeseeable causes beyond the control of and without fault or negligence of the ENGINEER no claim for damages shall be made by either party. Termination of the AGREEMENT or adjustment of the fee for the remaining services may be requested by either party if the overall delay from the unforeseen causes prevents completion of the work within six months after the specified completion date. Examples of unforeseen causes included but are not limited to: acts of God or a public enemy; acts of the LPA, DEPARTMENT, or other approving party not resulting from the ENGINEER's unacceptable services; fire; strikes; and floods.

If delays occur due to any cause preventing compliance with the PROJECT SCHEDULE, the ENGINEER shall apply in writing to the LPA for an extension of time. If approved, the PROJECT SCHEDULE shall be revised accordingly.

9. This certification is required by the Drug Free Workplace Act (30 ILCS 580). The Drug Free Workplace Act requires that no grantee or contractor shall receive a grant or be considered for the purpose of being awarded a contract for the procurement of any property or service from the DEPARTMENT unless that grantee or contractor will provide a drug free workplace. False certification or violation of the certification may result in sanctions including, but not limited to suspension of contract on grant payments, termination of a contract or grant and debarment of the contracting or grant opportunities with the DEPARTMENT for at least one (1) year but not more than (5) years.

For the purpose of this certification, "grantee" or "Contractor" means a corporation, partnership or an entity with twenty-five (25) or more employees at the time of issuing the grant or a department, division or other unit thereof, directly responsible for the specific performance under contract or grant of \$5,000 or more from the DEPARTMENT, as defined the Act.

The contractor/grantee certifies and agrees that it will provide a drug free workplace by:

- (a) Publishing a statement:
  - (1) Notifying employees that the unlawful manufacture, distribution, dispensing, possession or use of a controlled substance, including cannabis, is prohibited in the grantee's or contractor's workplace.
  - (2) Specifying actions that will be taken against employees for violations of such prohibition.
  - (3) Notifying the employee that, as a condition of employment on such contract or grant, the employee will:
    - (a) abide by the terms of the statement; and
    - (b) notify the employer of any criminal drug statute conviction for a violation occurring in the workplace no later than (5) days after such conviction.
- (b) Establishing a drug free awareness program to inform employees about:
  - (1) The dangers of drug abuse in the workplace;

- (2) The grantee's or contractor's policy to maintain a drug free workplace;
  - (3) Any available drug counseling, rehabilitation and employee assistance program; and
  - (4) The penalties that may be imposed upon an employee for drug violations.
- (c) Providing a copy of the statement required by subparagraph (a) to each employee engaged in the performance of the contract or grant and to post the statement in a prominent place in the workplace.
- (d) Notifying the contracting, or granting agency within ten (10) days after receiving notice under part (b) of paragraph (3) of subsection (a) above from an employee or otherwise, receiving actual notice of such conviction.
- (e) Imposing a sanction on, or requiring the satisfactory participation in a drug abuse assistance or rehabilitation program.
- (f) Assisting employees in selecting a course of action in the event drug counseling, treatment and rehabilitation is required and indicating that a trained referral team is in place.

Making a good faith effort to continue to maintain a drug free workplace through implementation of the Drug Free Workplace Act, the ENGINEER, LPA and the Department agree to meet the PROJECT SCHEDULE outlined in EXHIBIT B. Time is of the essence on this project and the ENGINEER's ability to meet the PROJECT SCHEDULE will be a factor in the LPA selecting the ENGINEER for future projects. The ENGINEER will submit progress reports with each invoice showing work that was completed during the last reporting period and work they expect to accomplish during the following period.

10. Due to the physical location of the project, certain work classifications may be subject to the Prevailing Wage Act (820 ILCS 130/0.01 et seq.).
11. For Preliminary Engineering Contracts:
- (a) That tracing, plans, specifications, estimates, maps and other documents prepared by the ENGINEER in accordance with this AGREEMENT shall be delivered to and become the property of the LPA and that basic survey notes, sketches, charts, CADD files, related electronic files, and other data prepared or obtained in accordance with this AGREEMENT shall be made available, upon request to the LPA or to the DEPARTMENT, without restriction or limitation as to their use. Any re-use of these documents without the ENGINEER involvement shall be at the LPA's sole risk and will not impose liability upon the ENGINEER.
  - (b) That all reports, plans, estimates and special provisions furnished by the ENGINEER shall conform to the current Standard Specifications for Road and Bridge Construction, Bureau of Local Roads and Streets Manual or any other applicable requirements of the DEPARTMENT, it being understood that all such furnished documents shall be approved by the LPA and the DEPARTMENT before final acceptance. During the performance of the engineering services herein provided for, the ENGINEER shall be responsible for any loss or damage to the documents herein enumerated while they are in the ENGINEER's possession and any such loss or damage shall be restored at the ENGINEER's expense.

**AGREEMENT SUMMARY**

Prime Consultant (Firm) Name	TIN/FEIN/SS Number	Agreement Amount
Hampton, Lenzini and Renwick, Inc.	36-2555986	\$3,600.00
Subconsultants	TIN/FEIN/SS Number	Agreement Amount
Subconsultant Total		
Prime Consultant Total		\$3,600.00
Total for all work		\$3,600.00

**AGREEMENT SIGNATURES**

Executed by the LPA:

Local Public Agency Type Local Public Agency

Attest:

The City of Belvidere of City of Belvidere

By (Signature & Date)

[Signature & Date box for LPA representative]

By (Signature & Date)

[Signature & Date box for Engineer representative]

Local Public Agency

City of Belvidere

Local Public Agency Type

City

Clerk

Title

[Title box for Engineer representative]

(SEAL)

Executed by the ENGINEER:

Prime Consultant (Firm) Name

Hampton, Lenzini and Renwick, Inc.

Attest:

By (Signature & Date)

*Kate Haseh Schulstad* 05/01/2026

Title

Associate

By (Signature & Date)

*Erica Spolar* 5/1/2026

Title

Executive Vice President

APPROVED:

Regional Engineer, Department of Transportation (Signature & Date)

[Signature & Date box for Regional Engineer]

Local Public Agency	Prime Consultant (Firm) Name	County	Section Number
City of Belvidere	Hampton, Lenzini and Renwick,	Boone	

**EXHIBIT A  
SCOPE OF SERVICES**

To perform or be responsible for the performance of the engineering services for the LPA, in connection with the PROJECT herein before described and enumerated below

HLR will use the previously developed FRA CRISI and Railroad Crossing Elimination grant applications developed for Phase 1 and 2 to prepare funding applications for future FRA, IDOT, and other applicable grants available for engineering and construction funding. With the proposed fee of \$3,600, HLR will prepare one grant application for Phase 2 and construction funding for the Appleton Road Grade Separation project for the FRA Railroad Crossing Elimination Program due June 8th, 2026.

The application may consist of the following:

- SF 424 (Application for Federal Assistance)
- Location Maps
- Updated Engineer's Probable Estimate of Cost
- Revised application narratives
- Application materials as discussed in the 25-26 NOFO.

Local Public Agency	Prime Consultant (Firm) Name	County	Section Number
City of Belvidere	Hampton, Lenzini and Renwick,	Boone	

**EXHIBIT B  
PROJECT SCHEDULE**

Notice to Proceed - May 4, 2026  
 Submit and Coordinate Grant Application: May - June 2026

Local Public Agency	Prime Consultant (Firm) Name	County	Section Number
City of Belvidere	Hampton, Lenzini and Renwick,	Boone	

**Exhibit C  
Qualification Based Selection (QBS) Checklist**

The LPA must complete Exhibit D. If the value meets or will exceed the threshold in 50 ILCS 510, QBS requirements must be followed. Under the threshold, QBS requirements do not apply. The threshold is adjusted annually. If the value is under the threshold with federal funds being used, federal small purchase guidelines must be followed.

Form Not Applicable (engineering services less than the threshold)

If yes Due date of submittal

Method(s) used for advertisement and dates of advertisement



**Hampton, Lenzini and Renwick, Inc.**

Civil Engineers • Structural Engineers • Land Surveyors • Environmental Specialists  
[www.hltrengineering.com](http://www.hltrengineering.com)

For our services we will be compensated at the following hourly rates which will be considered payment in full to Hampton, Lenzini and Renwick, Inc. for actual employee time utilized to provide the required services, said rates include overhead and burden costs plus profit. Other out-of-pocket expenses will be reimbursed at our actual cost.

Employee Classification	2026
PRINCIPAL /	\$ 245.00
ENGINEER 6	\$230.00
ENGINEER 5	\$ 215.00
ENGINEER 4	\$ 200.00
ENGINEER 3	\$ 185.00 /
ENGINEER 2	\$ 155.00
ENGINEER 1	\$ 140.00
STRUCTURAL 2	\$ 250.00
STRUCTURAL 1	\$ 215.00
TECHNICIAN 3	\$ 180.00
TECHNICIAN 2	\$ 145.00
TECHNICIAN 1	\$ 120.00
INTERN/TEMPORARY	\$ 80.00
LAND ACQUISITION	\$ 185.00
SURVEY 2	\$ 190.00
SURVEY 1	\$ 135.00
ENVIRONMENTAL 3	\$ 200.00
ENVIRONMENTAL 2	\$ 155.00
ENVIRONMENTAL 1	\$ 120.00
ADMINISTRATION 2	\$ 160.00
ADMINISTRATION 1	\$ 105.00

These rates will remain in effect through December 31, 2026. In the event our services are required after that date, we will submit revised rates to be utilized through December 31, 2027

# Memo

**To:** Mayor and City Council  
**From:** Brent Anderson, Director of Public Works  
**Date:** 5/6/2026  
**Re:** Parking Lot #7 Expansion and Enhancement Grant Projects – Material Testing

---

The City of Belvidere has received a proposal from Testing Service Corporation to complete the required material testing for the reconstruction of Municipal Parking Lot #7 in the amount of \$22,750.00. The material testing will include bituminous hot mix and concrete.

I would recommend approval of the proposal from Testing Service Corporation, in the amount of \$22,750.00, to complete material testing for the Parking Lot #7 Expansion and Enhancement Project. This work will be paid for from grant funds and capital funds.

May 5, 2026

Mr. Brent J. Anderson  
City of Belvidere - Public Works  
401 Whitney Boulevard, Suite 200  
Belvidere, IL 61008-3608

RE: P.N. 77,911- Revised  
Construction Material Engineering  
City of Belvidere Riverfront Development  
Contract #85787, FAU 5005 (North State Street)  
Section 23-00118-00-LS, Project No. R2EB (090)  
Job No. C-92-061-24  
Municipal Lot 7, East Lincoln Avenue & North State Street  
Belvidere, Illinois



**TESTING SERVICE CORPORATION**

**Local Office**

2235 23<sup>rd</sup> Avenue, Rockford, IL 61104-7334  
815.394.2562 • Fax 815.394.2566

**Corporate Office**

360 South Main Place, Carol Stream, IL 60188-2404  
630.462.2600

Dear Mr. Anderson:

Testing Service Corporation (TSC) is pleased to submit this revised proposal to provide the Construction Material Engineering for the referenced project. The broad objectives of our work will be to conduct and interpret tests, and to report our findings as directed by City of Belvidere - Public Works.

To schedule a Technician please call 815-394-2562 or email [asoni@tsccorp.com](mailto:asoni@tsccorp.com) or [rbumgarner@tsccorp.com](mailto:rbumgarner@tsccorp.com).

TSC is staffed and equipped to provide any of the following services that may be ordered by you:

- **Field Quality Control Services**
  - Observe proof-rolling operations.
  - Recommend amount of undercut using IDOT cone penetrometer procedure.
  - Perform in-place density tests on engineered fill/backfill and granular base course.
  - Test plastic concrete for slump, air content, temperature, unit weight and cast test cylinders.
  - Establish rolling pattern for bituminous concrete pavement mix with nuclear density gauge.
  - Pickup samples in the field for laboratory tests.
- **Bituminous Concrete Batch Plant Quality Control Services**
  - Daily hot bin and extraction analysis.
  - Sampling and testing of stockpile materials.
  - Check and adjust mixing formulas, as necessary.
  - Check temperatures of bitumen, drum and final mix.
  - Mold Marshall samples and check for stability and flow or determine density of Prepared (HMA) specimen by means of Gyratory Compactor.
  - Other tests as required by current IDOT procedures guide.
- **Portland Cement Concrete Batch Plant Quality Control Services**
  - Verify that current IDOT mix design is being used.
  - Check moisture content of fine aggregate.
  - Perform sieve analysis on stockpiled materials, as required by IDOT criteria.
  - Check the slump, air and temperature of final mix.

- Other tests, as required by current IDOT procedure guide.
- **Laboratory**
  - Perform laboratory compaction curve for each soil type used.
  - Determine density and thickness for core samples submitted by contractor.
  - Aggregate gradation and soundness analysis.
  - Perform compressive and flexural strength tests for concrete cylinders and beams.
  - Other tests, as required.
- **QA Manager Services**
  - Review test results performed by our technicians in accordance with IDOT specification.
  - Monitor and schedule site visits to test 20% of the total quantities for HMA and PCC mixes.
  - Complete the necessary paperwork for PCC and HMA testing and electronically submit them to IDOT and your office.

**TSC's field technicians are represented by Local 150 of the International Union of Operating Engineers.** Supervision of the testing, observation, and reporting is provided by a Registered Professional Engineer. Reports will generally be issued on a weekly basis as work progresses. Invoices will be issued monthly, subsequent to the reporting period.

**A budget amount of Twenty-Two Thousand Seven Hundred Fifty Dollars (\$22,750.00) is recommended for your project.** This estimate is based on a review of plans and specifications provided by ARC Design Resources, Inc. and prior experience on similar projects. TSC's itemized estimate is included in the "Assumptions and Estimated Fee" portion of this proposal. Factors such as weather and contractor efficiency and deviations from minimum testing and observation requirements may significantly impact the CME budget. Our fee is further subject to this proposal being accepted by you on or before July 31, 2026.

The Services performed by TSC under this proposal are now subject to prevailing wage regulations under Illinois law. Prevailing wage rates are established in June by the State of Illinois. Should the established wage be changed between the time of this proposal and the time of work, it will be necessary to revise this proposal so that the rates required by law are properly reflected. Prevailing wage categories are defined as follows:

Material Tester I: Hand coring and drilling for testing of materials; field inspection of uncured concrete and asphalt.

Material Tester II: Field inspection of welds, structural steel, fireproofing, masonry, soil, facade, reinforcing steel, formwork, cured concrete and concrete and asphalt batch plants, adjusting proportions of bituminous mixtures.

TSC's fees include TSC's services being performed subject to the attached General Conditions which are incorporated herein. Unless we receive written instructions to the contrary, invoices will be sent to:

Mr. Brent J. Anderson  
City of Belvidere - Public Works  
401 Whitney Boulevard, Suite 200  
Belvidere, IL 61008-3608  
Tel: (815) 544-9256  
Email: [banderson@belvidere.il.gov](mailto:banderson@belvidere.il.gov)

When completing the attached project data form, kindly indicate who is to receive copies of TSC's report and other project data.

Your consideration of our proposal is appreciated. We look forward to being of service to you on this project.

Respectfully Submitted,

TESTING SERVICE CORPORATION



Jeffrey L. Martin, P.E.  
Rockford Branch Manager

JLM/AAS/rb

Enc: General Conditions  
Project Data Sheet

CC: Mr. Bill Clasen, ARC Design Resources, Inc.  
Via Email: [bclasen@arcdesign.com](mailto:bclasen@arcdesign.com)

Prepared by



Arpit A. Soni  
Staff Engineer

Approved and accepted for \_\_\_\_\_ by:

\_\_\_\_\_  
(NAME)

\_\_\_\_\_  
(TITLE)

\_\_\_\_\_  
(DATE)

**SCHEDULE OF FEES**

CONSTRUCTION MATERIALS ENGINEERING SERVICES

ITEM I      FIELD SERVICES

A.	Material Tester I	Per Hour: \$ 130.00
B.	Material Tester II	Per Hour: \$ 135.00
C.	Transportation, Light Vehicle	Per Trip: \$ 70.00
	<p>The time is portal-to-portal from the office servicing the project.          Increase hourly rate by 1.5 for over 8.0 hours per day on Saturday.          Increase hourly rate by 1.7 for Sunday or Holiday work.          The minimum trip charge for 0 to 4 hours is four (4) hours and for          4 to 8 hours is eight (8) hours Monday through Friday and eight (8)          hours on Saturday and Sunday.</p> <p>Engineering services for summary report preparation are invoiced          at the Graduate Engineer Rate.</p>	
D.	Use of Nuclear Moisture/Density Gauge	Per Day: \$ 50.00
E.	Pickup Concrete Test Samples	
	1. Fewer than 20 Cylinders at Grade Level	Per Trip: \$ 120.00
	2. 20 or more Cylinders or Cylinders in Basement or on Elevated Deck or Concrete Beams	Per Trip: \$ 160.00
F.	Structural Steel Test Equipment	
	1. Ultrasonic Flaw Detector	Per Day: \$ 100.00
	2. Magnetic Particle Yoke	Per Day: \$ 50.00
G.	Fire-Proofing	
	1. Cohesion Test Supplies	Per Day: \$ 75.00
	2. Density Test	Each: \$ 50.00

ITEM II      LABORATORY SERVICES

A.	Soils	
	1. Compaction Curve to establish the Maximum Dry Unit weight and optimum water content	
	a. Modified (AASHTO T180, ASTM D1557)	Each: \$ 250.00
	b. Standard (AASHTO T99, ASTM D698)	Each: \$ 250.00

c. Add for Methods B, C, or D	Each: \$	20.00
2. Thin-Walled Tube Samples		
a. Combined Water Content & Dry Unit Weight Determination	Each: \$	20.00
b. Unconfined Compressive Strength	Each: \$	23.00
B. Portland Cement Concrete/Aggregates		
1. Concrete Test Cylinders (4"x8")		
a. Compressive Strength	Each: \$	17.00
b. Spares/Handling Charge	Each: \$	17.00
c. Trim End of Specimen When Necessary	Additional: \$	15.00
2. Concrete Test Cylinders (6"x12")		
a. Compressive Strength	Each: \$	20.00
b. Spares/Handling Charge	Each: \$	20.00
c. Trim End of Specimen When Necessary	Additional: \$	15.00
3. Concrete Beams for Flexural Strength Testing	Each: \$	50.00
4. Mortar Cubes		
a. Compressive Strength	Each: \$	19.00
b. 2" Cube Mold	Per Day: \$	10.00
5. Contractor Made Cylinders	Each: \$	40.00
a. Trim End of Specimen When Necessary	Additional: \$	20.00
6. Evaluation of Mortars for Plain & Reinforced Masonry		
a. Pre-Construction	Each: \$	350.00
b. Cement/Aggregate Ratio	Each: \$	75.00
7. Masonry Block Prisms	Each: \$	50.00
8. Sieve Analysis		
a. Washed w/200 Sieve	Each: \$	125.00
b. Unwashed	Each: \$	100.00
C. Bituminous Concrete		
1. Extraction Analysis		
a. Unwashed	Each: \$	250.00
b. Washed	Each: \$	250.00
2. Compaction of Bituminous Mixture by Gyratory Methods and Bulk Specific Gravity Test	Set of Two \$	225.00
3. Theoretical Maximum Specific Gravity of Paving Mixture	Each: \$	110.00

- 4. Determining Asphalt Content by Ignition Oven: Each: \$ 125.00
- 5. Determining Asphalt Content by Ignition Oven and Washed Gradation: Each: \$ 225.00
- 6. Bulk Density of Core Specimens Each: \$ 70.00

ITEM III    CONSULTATION AND REPORT PREPARATION

- A. Registered Professional Engineer, Principal Per Hour: \$ 250.00
- B. Registered Professional Engineer Per Hour: \$ 200.00
- C. Graduate Civil Engineer Per Hour: \$ 170.00
- D. Daily Engineering Services Per Hour: \$ 170.00
- E. Transportation
  - 1. Light Vehicle Trip Charge: \$ 70.00
  - 2. Light Vehicle (Over 100 miles round trip) Per Mile: \$ 0.72
  - 3. Public Transportation Cost + 10%

The above rates are valid through December 31, 2026.

**ASSUMPTIONS & ESTIMATED FEE**

The following estimate is based on our current cost structure. **Please note that the below recommended budget amount for testing is an estimate and is dependent on the contractor's schedule, efficiency and many other factors.**

<b>Earth Excavation / Aggregate Base Course / Trench Backfill</b>					
Item No.	ITEMS	Unit	Quantity	Unit Price	Amount
1	Material Tester II	Hour	64	135.00	\$ 8,640.00
2	Material Tester II (Overtime)	Hour		202.00	\$ 0.00
3	Travel, Light Vehicle	Trip	10	70.00	\$ 700.00
4	Nuclear Moisture Density Gauge	Day	9	50.00	\$ 450.00
5	Soil, Water Content and Dry Unit Weight Determination	Each		20.00	\$ 0.00
6	Laboratory Compaction Curve Soil (Standard)	Each	3	250.00	\$ 750.00
7	Sieve Analysis, Aggregate	Each		125.00	\$ 0.00
Subtotal					\$ 10,540.00

Estimate Basis – Estimate four (4) 4-hour and six (6) 8-hour trips for proof-roll observation, subgrade observation and density testing associated with earth excavation, fill/backfill and aggregate base course.

<b>Portland Cement Concrete/Field</b>					
Item No.	ITEMS	Unit	Quantity	Unit Price	Amount
1	Material Tester I	Hour	32	130.00	\$ 4,160.00
2	Material Tester I (Overtime)	Hour		195.00	\$ 0.00
3	Travel, Light Vehicle	Trip	8	70.00	\$ 560.00
4	Pickup Test Samples	Each	8	120.00	\$ 960.00
5	Concrete Test Cylinders (6" x 12")	Each		20.00	\$ 0.00
6	Concrete Test Cylinders (4" x 8")	Each	48	17.00	\$ 816.00
7	Sieve Analysis, Aggregate	Each		125.00	\$ 0.00
Subtotal					\$ 6,496.00

Estimate Basis – Estimate eight (8) 4-hour trips for concrete testing for sidewalks, driveway pavement, concrete collar, light pole/sign foundations, and related concrete items.

Bituminous Concrete/Field					
Item No.	ITEMS	Unit	Quantity	Unit Price	Amount
1	Material Tester I	Hour	20	130.00	\$ 2,600.00
2	Material Tester I (Overtime)	Hour		195.00	\$ 0.00
3	Travel, Light Vehicle	Trip	3	70.00	\$ 210.00
4	Pickup Test Samples	Each		120.00	\$ 0.00
5	Nuclear Moisture Density Gauge	Day	3	50.00	\$ 150.00
6	Bituminous Concrete Extraction Analysis	Each		225.00	\$ 0.00
7	Compaction of Bituminous Mixture by Gyratory Methods and Bulk Specific Gravity Test	Set of Two		225.00	\$ 0.00
8	Density of Core Samples	Each		70.00	\$ 0.00
Subtotal					\$ 2,960.00

Estimate Basis – Estimate one (1) 4-hour and two (2) 8-hour trips for HMA field QA density testing for binder and surface course paving.

Project Coordination & Report Preparation					
Item No.	ITEMS	Unit	Quantity	Unit Price	Amount
1	Project Engineer	Hour		170.00	\$ 0.00
2	QA Manager	Hour	16	170.00	\$ 2,720.00
Subtotal					\$ 2,720.00

TSC's base fee schedule includes up to three copies of each report.

Estimated Total: \$ 22,716.00

RECOMMENDED BUDGET: \$ 22,750.00



## TESTING SERVICE CORPORATION

# GENERAL CONDITIONS

## Geotechnical and Construction Services

**1. PARTIES AND SCOPE OF WORK:** If Client is ordering the services on behalf of another, Client represents and warrants that Client is the duly authorized agent of said party for the purpose of ordering and directing said services, and in such case the term "Client" shall also include the principal for whom the services are being performed. Prices quoted and charged by TSC for its services are predicated on the conditions and the allocations of risks and obligations expressed in these General Conditions. Unless otherwise stated in writing, Client assumes sole responsibility for determining whether the quantity and the nature of the services ordered by Client are adequate and sufficient for Client's intended purpose. Unless otherwise expressly assumed in writing, TSC's services are provided exclusively for Client. TSC shall have no duty or obligation other than those duties and obligations expressly set forth in this Agreement. TSC shall have no duty to any third party. Client shall communicate these General Conditions to each and every party to whom the Client transmits any report prepared by TSC. Ordering services from TSC shall constitute acceptance of TSC's proposal and these General Conditions.

**2. SCHEDULING OF SERVICES:** The services set forth in this Agreement will be accomplished in a timely and workmanlike manner. If TSC is required to delay any part of its services to accommodate the requests or requirements of Client, regulatory agencies, or third parties, or due to any cause beyond its reasonable control, Client agrees to pay such additional charges, if any, as may be applicable.

**3. ACCESS TO SITE:** TSC shall take reasonable measures and precautions to minimize damage to the site and any improvements located thereon as a result of its services or the use of its equipment; however, TSC has not included in its fee the cost of restoration of damage which may occur. If Client desires or requires TSC to restore the site to its former condition, TSC will, upon written request, perform such additional work as is necessary to do so and Client agrees to pay to TSC the cost thereof plus TSC's normal markup for overhead and profit.

**4. CLIENT'S DUTY TO NOTIFY ENGINEER:** Client represents and warrants that Client has advised TSC of any known or suspected hazardous materials, utility lines and underground structures at any site at which TSC is to perform services under this Agreement. Unless otherwise agreed in writing, TSC's responsibility with respect to underground utility locations is to contact the Illinois Joint Utility Locating Information for Excavators for the location of public, but not private, utilities.

**5. DISCOVERY OF POLLUTANTS:** TSC's services shall not include investigation for hazardous materials as defined by the Resource Conservation Recovery Act, 42 U.S.C. § 6901, et. seq., as amended ("RCRA") or by any state or Federal statute or regulation. In the event that hazardous materials are discovered and identified by TSC, TSC's sole duty shall be to notify Client.

**6. MONITORING:** If this Agreement includes testing construction materials or observing any aspect of construction of improvements, Client's construction personnel will verify that the pad is properly located and sized to meet Client's projected building loads. Client shall cause all tests and inspections of the site, materials and work to be timely and properly performed in accordance with the plans, specifications, contract documents, and TSC's recommendations. No claims for loss, damage or injury shall be brought against TSC unless all tests and inspections have been so performed and unless TSC's recommendations have been followed.

TSC's services shall not include determining or implementing the means, methods, techniques or procedures of work done by the contractor(s) being monitored or whose work is being tested. TSC's services shall not include the authority to accept or reject work or to in any manner supervise the work of any contractor. TSC's services or failure to

perform same shall not in any way operate or excuse any contractor from the performance of its work in accordance with its contract. "Contractor" as used herein shall include subcontractors, suppliers, architects, engineers and construction managers.

Information obtained from borings, observations and analyses of sample materials shall be reported in formats considered appropriate by TSC unless directed otherwise by Client. Such information is considered evidence, but any inference or conclusion based thereon is, necessarily, an opinion also based on engineering judgment and shall not be construed as a representation of fact. Subsurface conditions may not be uniform throughout an entire site and ground water levels may fluctuate due to climatic and other variations. Construction materials may vary from the samples taken. Unless otherwise agreed in writing, the procedures employed by TSC are not designed to detect intentional concealment or misrepresentation of facts by others.

**7. DOCUMENTS AND SAMPLES:** Client is granted an exclusive license to use findings and reports prepared and issued by TSC and any sub-consultants pursuant to this Agreement for the purpose set forth in TSC's proposal provided that TSC has received payment in full for its services. TSC and, if applicable, its sub-consultant, retain all copyright and ownership interests in the reports, boring logs, maps, field data, field notes, laboratory test data and similar documents, and the ownership and freedom to use all data generated by it for any purpose. Unless otherwise agreed in writing, test specimens or samples will be disposed immediately upon completion of the test. All drilling samples or specimens will be disposed sixty (60) days after submission of TSC's report.

**8. TERMINATION:** TSC's obligation to provide services may be terminated by either party upon (7) seven days prior written notice. In the event of termination of TSC's services, TSC shall be compensated by Client for all services performed up to and including the termination date, including reimbursable expenses. The terms and conditions of these General Conditions shall survive the termination of TSC's obligation to provide services.

**9. PAYMENT:** Client shall be invoiced periodically for services performed. Client agrees to pay each invoice within thirty (30) days of its receipt. Client further agrees to pay interest on all amounts invoiced and not paid or objected to in writing for valid cause within sixty (60) days at the rate of twelve (12%) per annum (or the maximum interest rate permitted by applicable law, whichever is the lesser) until paid and TSC's costs of collection of such accounts, including court costs and reasonable attorney's fees.

**10. WARRANTY:** TSC's professional services will be performed, its findings obtained and its reports prepared in accordance with these General Conditions and with generally accepted principles and practices. In performing its professional services, TSC will use that degree of care and skill ordinarily exercised under similar circumstances by members of its profession. In performing physical work in pursuit of its professional services, TSC will use that degree of care and skill ordinarily used under similar circumstances. This warranty is in lieu of all other warranties or representations, either express or implied. Statements made in TSC reports are opinions based upon engineering judgment and are not to be construed as representations of fact.

Should TSC or any of its employees be found to have been negligent in performing professional services or to have made and breached any express or implied warranty, representation or contract, Client, all parties claiming through Client and all parties claiming to have in any way relied upon TSC's services or work agree that the maximum aggregate amount of damages for which TSC, its officers, employees and agents shall be liable is limited to \$50,000 or the total amount of the fee paid to TSC for its services performed with respect to the project, whichever amount is greater.

In the event Client is unwilling or unable to limit the damages for which TSC may be liable in accordance with the provisions set forth in the preceding paragraph, upon written request of Client received within five days of Client's acceptance of TSC's proposal together with payment of an additional fee in the amount of 5% of TSC's estimated cost for its services (to be adjusted to 5% of the amount actually billed by TSC for its services on the project at time of completion), the limit on damages shall be increased to \$500,000 or the amount of TSC's fee, whichever is the greater. This charge is not to be construed as being a charge for insurance of any type, but is increased consideration for the exposure to an award of greater damages.

**11. INDEMNITY:** Subject to the provisions set forth herein, TSC and Client hereby agree to indemnify and hold harmless each other and their respective shareholders, directors, officers, partners, employees, agents, subsidiaries and division (and each of their heirs, successors, and assigns) from any and all claims, demands, liabilities, suits, causes of action, judgments, costs and expenses, including reasonable attorneys' fees, arising, or allegedly arising, from personal injury, including death, property damage, including loss of use thereof, due in any manner to the negligence of either of them or their agents or employees or independent contractors. In the event both TSC and Client are found to be negligent or at fault, then any liability shall be apportioned between them pursuant to their pro rata share of negligence or fault. TSC and Client further agree that their liability to any third party shall, to the extent permitted by law, be several and not joint. The liability of TSC under this provision shall not exceed the policy limits of insurance carried by TSC. Neither TSC nor Client shall be bound under this indemnity agreement to liability determined in a proceeding in which it did not participate represented by its own independent counsel. The indemnities provided hereunder shall not terminate upon the termination or expiration of this Agreement, but may be modified to the extent of any waiver of subrogation agreed to by TSC and paid for by Client.

**12. SUBPOENAS:** TSC's employees shall not be retained as expert witnesses except by separate, written agreement. Client agrees to pay TSC pursuant to TSC's then current fee schedule for any TSC employee(s) subpoenaed by any party as an occurrence witness as a result of TSC's services.

**13. OTHER AGREEMENTS:** TSC shall not be bound by any provision or agreement (i) requiring or providing for arbitration of disputes or controversies arising out of this Agreement or its performance, (ii) wherein TSC waives any rights to a mechanics lien or surety bond claim; (iii) that conditions TSC's right to receive payment for its services upon payment to Client by any third party or (iv) that requires TSC to indemnify any party beyond its own negligence. These General Conditions are notice, where required, that TSC shall file a lien whenever necessary to collect past due amounts. This Agreement contains the entire understanding between the parties. Unless expressly accepted by TSC in writing prior to delivery of TSC's services, Client shall not add any conditions or impose conditions which are in conflict with those contained herein, and no such additional or conflicting terms shall be binding upon TSC. The unenforceability or invalidity of any provision or provisions shall not render any other provision or provisions unenforceable or invalid. This Agreement shall be construed and enforced in accordance with the laws of the State of Illinois. In the event of a dispute arising out of or relating to the performance of this Agreement, the breach thereof or TSC's services, the parties agree to try in good faith to settle the dispute by mediation under the Construction Industry Mediation Rules of the American Arbitration Association as a condition precedent to filing any demand for arbitration, or any petition or complaint with any court. Paragraph headings are for convenience only and shall not be construed as limiting the meaning of the provisions contained in these General Conditions.

**PROJECT DATA SHEET**



**TESTING SERVICE CORPORATION**

General Information: \_\_\_\_\_

Project Name: \_\_\_\_\_

Project Address: \_\_\_\_\_

City/State/Zip: \_\_\_\_\_

County: \_\_\_\_\_

Project Manager: \_\_\_\_\_

Email: \_\_\_\_\_

Telephone: \_\_\_\_\_

Site Contact: \_\_\_\_\_

Email: \_\_\_\_\_

Telephone: \_\_\_\_\_

Send Invoice to: \_\_\_\_\_

Purchase Order Number: \_\_\_\_\_

Attention: \_\_\_\_\_

Company: \_\_\_\_\_

Address: \_\_\_\_\_

City/State/Zip: \_\_\_\_\_

Email: \_\_\_\_\_

Telephone: \_\_\_\_\_

Cell Phone: \_\_\_\_\_

If waivers are required, please provide the Owner's name here \_\_\_\_\_

IMPORTANT NOTES: \_\_\_\_\_

\_\_\_\_\_

\_\_\_\_\_

Completed by: \_\_\_\_\_

Signature: \_\_\_\_\_

Name: \_\_\_\_\_

Date: \_\_\_\_\_

Distribute Reports as Follows:

Name: \_\_\_\_\_

Company: \_\_\_\_\_

Address: \_\_\_\_\_

City/State/Zip: \_\_\_\_\_

Email: \_\_\_\_\_

Telephone: \_\_\_\_\_

Cell Phone: \_\_\_\_\_

Name: \_\_\_\_\_

Company: \_\_\_\_\_

Address: \_\_\_\_\_

City/State/Zip: \_\_\_\_\_

Email: \_\_\_\_\_

Telephone: \_\_\_\_\_

Name: \_\_\_\_\_

Company: \_\_\_\_\_

Address: \_\_\_\_\_

City/State/Zip: \_\_\_\_\_

Email: \_\_\_\_\_

Telephone: \_\_\_\_\_

Name: \_\_\_\_\_

Company: \_\_\_\_\_

Address: \_\_\_\_\_

City/State/Zip: \_\_\_\_\_

Email: \_\_\_\_\_

Telephone: \_\_\_\_\_

# Memo

**To:** Mayor and City Council  
**From:** Jordan Keck, Assistant Director of Public Works  
**Date:** 5/6/2026  
**Re:** Purchase of Wheeled Excavator – Street Department

---

The Street Department's Fiscal Year 2027 budget includes \$350,000 for a new wheeled excavator to replace our 1999 Komatsu PW170ES-6. We have received the following proposal for a new wheeled excavator through Sourcewell Cooperative Contract 011723-JDC:

1. West Side Tractor Sales      2026 John Deere 190G FT4 Excavator      \$345,532.85  
    3110 Prairie Road  
    Rockford, IL 61102

I would recommend the purchase of the 2026 John Deere 190G FT4 Excavator from West Side Tractor Sales in the amount of \$345,532.85. This equipment will be paid for from capital funds.



**JOHN DEERE**

**WEST SIDE TRACTOR SALES**

3110 Prairie Road Rockford IL 61102

(815) 961-3160

Ron Svartoi - Sales Representative - rons@wtsales.com

**WEST SIDE**



April 30, 2026

**CITY OF BELVIDERE PUBLIC WORKS DEPT  
515 WEST LOCUST ST  
BELVIDERE, IL**

Sourcewell ID #

**2026 John Deere 190G FT4 Excavator**  
**SOURCEWELL Cooperative Contract 011723-JDC**

*Please note that this quote is valid for 30 days.*

Code	Machine Configuration Description	Unit Price
All the prices in the detailed sections are Per machine basis. Qty (1)		
7391FF	190GW FT4 Wheeled Excavator	430,140.00
170K	JDLINK™	-
5480	Front & Rear Outriggers	6,366.00
6870	Variable Geometry Boom	15,948.00
		<b>List Price \$ 452,454.00</b>
		<b>Discount 43.0% \$ 194,555.22</b>
		<b>Net Price \$ 257,898.78</b>

Custom Jobs Description	Qty	Price
Factory Freight Destination Rockford, IL 61102	1	6,750.00
Dir provide Pre-Delivery Inspection, Supplies and Fuel Fill	1	2,400.00
Dealer Provided Delivery	1	900.00
Labor for field installed kits	1	4,162.50
Extended Warranty: • 36 Mths - 3000 Hr Extended PT+H Warranty Machine Only	1	2,603.75
Auxiliary Hydraulics. Attachment Combo Kit	1	817.65
JRB Coupler	1	10,448.25
Roto Bec Rotating Grapple	1	53,345.00
60" Ditching Bucket	1	5,226.55
36" Excavating Bucket	1	6,453.01
Autolube System	1	14,027.37
Hoses for Grapple & Case Drain	1	2,500.00
<b>Total Price</b>		<b>\$ 109,634.07</b>

Quote Summary (per unit)		Prices
<b>Item Description</b>		
Machine Net Price		\$ 257,898.78
Custom Jobs		\$ 109,634.07
<b>Total Net Price</b>	<b>Quantity (1)</b>	<b>\$ 367,532.85</b>

Less Trade-in	
1999 Komatsu PW170ES-6K--(w/ Grapple, 36" Bkt, 60" Bkt) with 10592 hours	22,000.00

**Net Price less Trade-Ins \$ 345,532.85**

**Expected Machine Delivery Date: July 1, 2026**

**Warranty Terms**

190G FT4 includes • 36 Mths - 3000 Hr Extended PT+H Warranty Machine Only

## Power Attachment RPA3045R43 RGP-900

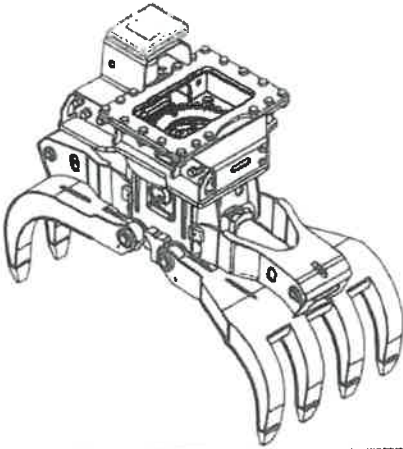

Max load:	n/a lb	n/a kg
Volume:	.25 cord of 8 ft	.91 m <sup>3</sup>
Area tip to tip:	4.00 ft <sup>2</sup>	.37 m <sup>2</sup>
Rotator lifting capacity:	90000 lb	40823 kg
Torque at relief pressure:	148710 lb-in	16802 Nm
	2200 psi	152 bars
Weight:	2760 lb	1252 kg

Rotator Maximum pressure: 5000 psi 345 bars Recommended flow: 28 gpm 106 l/min

Rotator recommended flow will produce a maximum speed of 15 rpm

Cylinder	Diameter	Recommended pressure	Pressure range	Flow range	Lock valves
Standard	3 1/2" (89 mm)	4000 psi (276 bars)	3000-5000 psi (207-345 bars)	14-20 gpm (53-76 l/min.)	no

Grapple cylinder maximum flow will theoretically produce a complete grapple open/close cycle in 4 seconds.

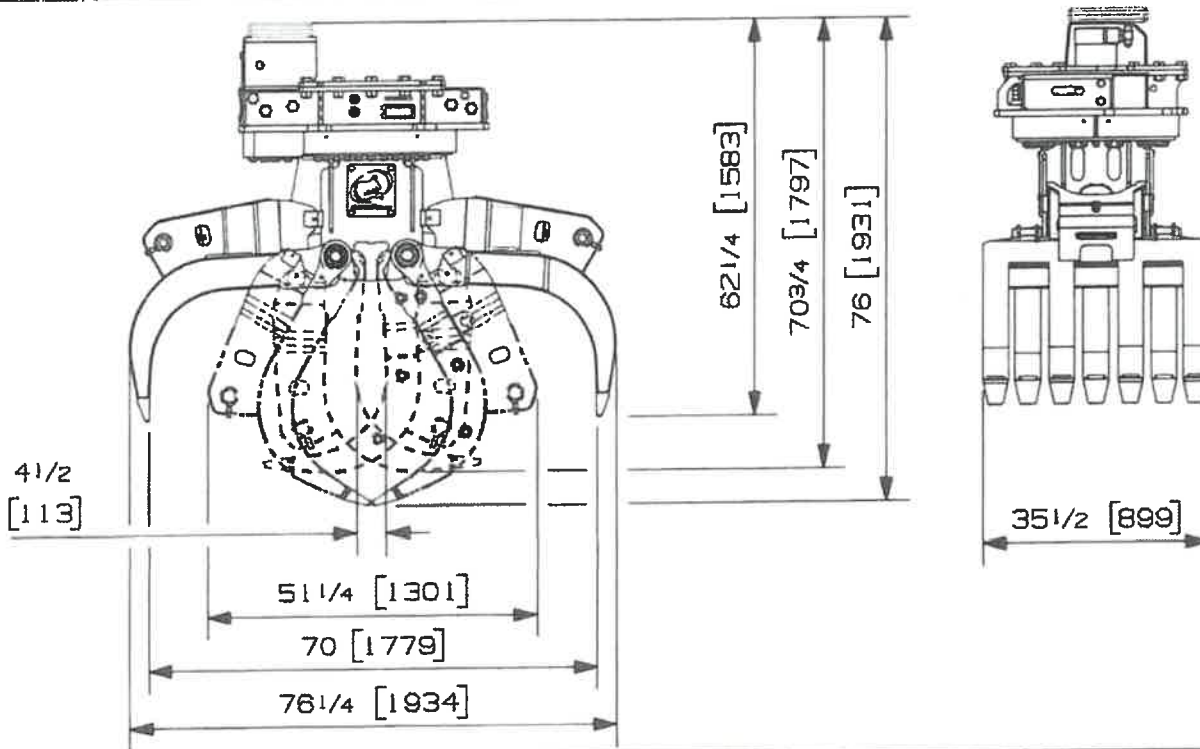

### Options:

- Mini heel set (73 lbs / 33 kg)
- Load holding valve (20 lbs / 9 kg)
- Synchronisation + CounterBalance valve option (N/D)
- Saw bundle 404 (saw included) (520 lbs / 236 kg)
- Saw bundle 750 (saw included) (760 lbs / 345 kg)
- See also RGP-900 for more options

web site: [www.rotobec.com](http://www.rotobec.com)

email: [rotobec@rotobec.com](mailto:rotobec@rotobec.com)

Rotobec Inc.: Head office serving OEM's and Eastern Canada Ph: (418) 383-3002 Fax (418) 383-5334  
 Rotobec West: Branch serving Western Canada and Western USA Ph: (250) 765-1161 Fax (250) 765-0035  
 Rotobec USA: Branch serving Eastern and Central USA Ph: (603) 444-2103 Fax (603) 444-0327

We reserve the right to change specifications and to improve our products without notice or obligation.

07008-0459  
23/11/18 D.L.

# Memo

**To:** Mayor and City Council  
**From:** Jordan Keck, Assistant Director of Public Works  
**Date:** 5/6/2026  
**Re:** Purchase of Mini Excavator – Street Department

---

The Street Department's Fiscal Year 2027 budget includes \$150,000 for a new mini excavator to replace our 2004 Vermeer CX234. We have received the following proposal for a new mini excavator through Sourcewell Cooperative Contract 011723-JDC:

1. West Side Tractor Sales      2026 John Deere 60 P Mini Excavator      \$140,446.49  
    3110 Prairie Road  
    Rockford, IL 61102

I would recommend the purchase of the 2026 John Deere 60 P Mini Excavator from West Side Tractor Sales in the amount of \$140,446.49. This equipment will be paid for from capital funds.

**WEST SIDE TRACTOR SALES**3110 Prairie Road Rockford IL 61102  
(815) 961-3160

Ron Svartoiem - Sales Representative - rons@wstsales.com



April 30, 2026

**CITY OF BELVIDERE PUBLIC WORKS DEPT**  
**515 WEST LOCUST ST**  
**BELVIDERE, IL**

Sourcewell ID #

**2026 John Deere 60 P Mini Excavator**  
**SOURCEWELL Cooperative Contract 011723-JDC***Please note that this quote is valid for 30 days.*

Code	Machine Configuration Description	Unit Price
All the prices in the detailed sections are Per machine basis. Qty (1)		
0190FF	60 P-Tier Compact Excavator	108,837.00
0202	Destination Code - United States	-
0259	English Customer Delivery Packet	-
0408	Configuration 8 - Cab, Rubber, Susp, Long Arm + EX C/W, Angle Blade	12,006.00
	<b>List Price</b>	<b>\$ 120,843.00</b>
	<b>Discount 27.0%</b>	<b>\$ 32,627.61</b>
	<b>Net Price</b>	<b>\$ 88,215.39</b>

Custom Jobs Description	Qty	Price
Factory Freight Destination Rockford, IL 61102	1	1,321.44
Dlr provide Pre-Delivery Inspection, Supplies and Fuel Fill	1	2,600.00
Dealer Provided Delivery	1	700.00
Labor for field installed kits	1	5,512.50
Extended Warranty: • 36 Mths - 3000 Hr Extended PT+H Warranty Machine Only	1	625.71
Pin Kit - Pin Grabber Coupler Attach - 50/60	3	1,764.00
Hydraulic Quick Disconnect Kit for Selector Valve	1	221.33
Thumb, 50 / 60 Size Pin Grabber Compact Excavator, w/ Selector Valve	1	3,880.00
60 Size Hydraulic Variable Pin Grab Coupler	1	9,122.67
42" Ditching, 9.6 c. ft. 60 Size Pin Grabber Coupler Bucket	1	2,992.00
24" Heavy Duty 7.5 c. ft.; 60 Size Pin Grabber Coupler Bucket	1	3,048.00
NPK PH3 HAMMER ASSEMBLY	1	16,962.00
FECON FMX MOWER TOP CAP-(CUSTOMER INSTALL)	1	2,622.67
RADIO	1	858.77
<b>Total Price</b>	<b>\$</b>	<b>52,231.10</b>

Quote Summary (per unit)		Prices
<b>Item Description</b>		
Machine Net Price		\$ 88,215.39
Custom Jobs		\$ 52,231.10
<b>Total Net Price</b>	<b>Quantity (1)</b>	<b>\$ 140,446.49</b>

✕ **Expected Machine Delivery Date: 60P Available Today; June 1, 2026 w/ Attachments****Warranty Terms**

60 P includes • Full Machine Warranty for 24 Mo OR 2000 Hr whichever occurs first • 36 Mths - 3000 Hr Extended PT+H Warranty Machine Only